

Installation Manual
**ULTRA ADVANTAGE
SEQUENTIAL
SERVO ROLL FEED**

Models SRF-5 / 8 / 12 / 16 / 20 / 24 / 28 / 32 / 36

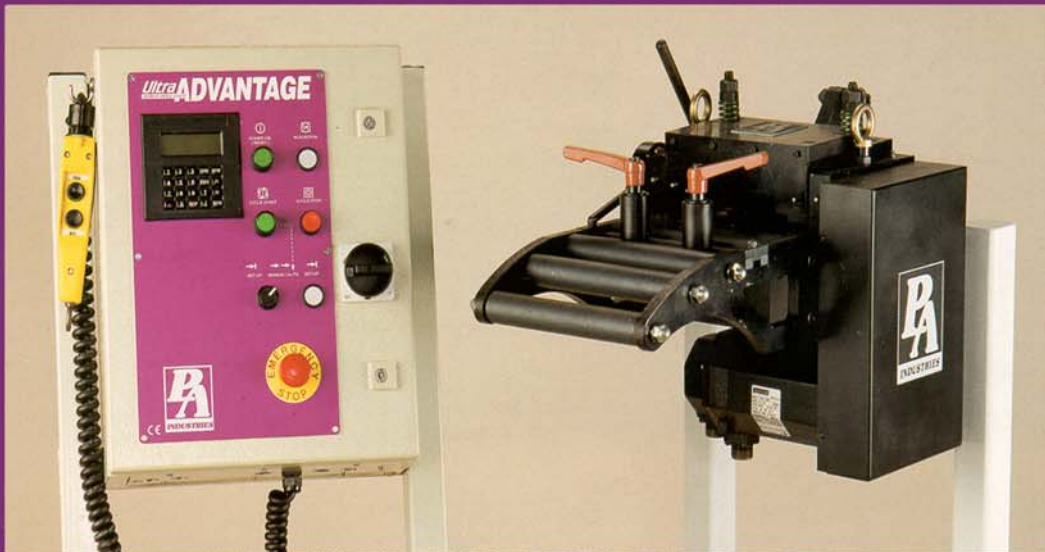

P/A INDUSTRIES INC.

522 Cottage Grove Road ■ Bloomfield, Connecticut 06002-3191 U.S.A.

Toll Free 1-800-243-8306 ■ Worldwide 1-860-243-8306 ■ Fax 1-860-242-4870

Website <http://www.pa.com> ■ E-Mail service@pa.com

TABLE OF CONTENTS

DESCRIPTION	PAGE
1 INSTALLATION	3
1.1 MECHANICAL INSTALLATION	3
1.2 ELECTRICAL INSTALLATION	5
1.3 LOADING THE FEED (PRESS APPLICATION)	6
1.4 LOADING THE FEED (PINCHING BENCH APPLICATION)	7
1.5 USING A BACKUP MOVE	7
1.6 RUNNING THE FEED	8
2 PNEUMATIC PILOT RELEASE	9
3 MAINTENANCE	11
4 ROLL FEED PARTS LIST	12
WARNING	16
SAFETY PROGRAM	16
WARRANTY	16

1 INSTALLATION

1.1 MECHANICAL INSTALLATION

The *Ultra Advantage Sequential Servo Roll Feed* is supplied with an adjustable mounting bracket. The feed should be securely mounted to the press frame. (A transition bracket is sometimes required in certain applications.) The feed should be centered, square, and perpendicular to the pass line of the press. It should be mounted at a height that will accommodate the appropriate die sets. The feed has a pass line height adjustment of ± 1.2 inches. (**Note:** The centerline of the Feeder is **NOT** the centerline of the rolls.) Refer to **FIGURE 1** for dimensions.

The feeder may be used to push or pull strip stock through the die.

If pilot locating pins are used in your die sets, the optional mechanical roll release bracket should be attached to the press ram. It must be mounted in such a way as to provide roll release at the proper time and be adjustable for different die sets.

If the optional electro-pneumatic piloting is used, another cam switch will be necessary for controlling feed roll opening and closing.

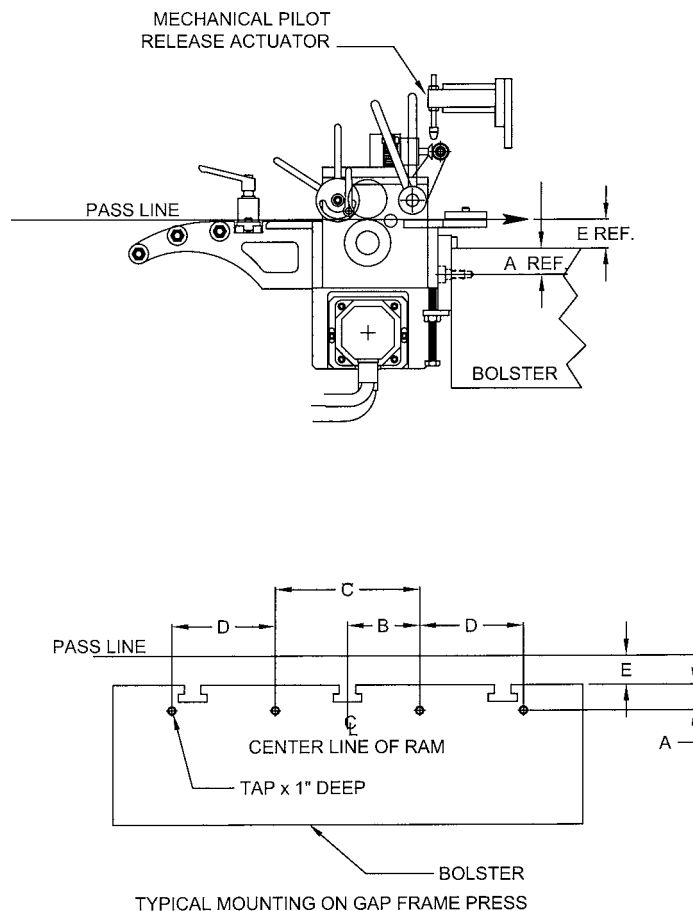

FIGURE 1

MOUNTING HOLE DIMENSIONS

ENGLISH-INCHES

DIMENSION	SRF-5	SRF-8	SRF-12	SRF-16/20/24/28/32/36
A	1.97	1.97	1.97	1.97
B	3.15	3.94	3.94	3.94
C	6.30	7.87	7.87	7.87
D	-	-	-	5.91
TAP	M16	M16	M16	M16
E MIN.	2.4	2.4	2.4	2.4
PASS LINE	+2.4	+2.4	+2.4	+2.4
ADJUSTMENT	-0.0	-0.0	-0.0	-0.0
WIDTH OF MTG. PLATE	12.13	14.88	18.82	22.76 / 26.69 / 30.63 34.57 / 38.50 / 43.19

METRIC- (MM)

DIMENSION	SRF-5	SRF-8	SRF-12	SRF-16/20/24/28/32/36
A	50	50	50	50
B	80	100	100	100
C	160	200	200	200
D	-	-	-	150
TAP	M16	M16	M16	M16
E MIN.	60	60	60	60
PASS LINE	+60	+60	+60	+60
ADJUSTMENT	-0.0	-0.0	-0.0	-00.0
WIDTH OF MTG. PLATE	308	378	478	578 / 678 / 778 878 / 978 / 1097

FIGURE 2

1.2 ELECTRICAL INSTALLATION

The *Ultra Advantage Sequential Servo Roll Feed* has been designed to make electrical connections quickly and easily. All that is required is a "clean" 220 VAC single-phase 15-ampere source that must be connected to the main disconnect switch. It is recommended that #12 MTW (Machine Tool Wire) be used for the primary power supply input.

The inputs and outputs to your process equipment (press, punching bench, etc.,) control (i.e. Emergency Stop, Feed Cam Signal /Feed signal, Reset Cam Signal/Reset signal, Pilot Release Cam Signal,) must also be connected for proper operation.

The motor connects by factory installed "Amphenol" (Military Specifications) Quick connectors.

For more detailed wiring information, refer to Electrical Schematic:

A-18164-06 – Ultra Advantage Sequential-US-standard.

IMPORTANT!

A #12 MTW GROUNDING CONDUCTOR MUST BE INSTALLED FOR PROPER MACHINE GROUNDING.

NOTE:

All connections should be made in accordance with National Electrical Code (NEC) requirements and must comply with all local ordinances.

NOTE:

A word about electrical "noise" - Most pressroom environments contain considerable electrical noise. It is emitted from electro-mechanical press relays, contacts, and solenoids. While the *Ultra Advantage Sequential Servo Roll Feed* has been designed to minimize "self generated" electrical noise, it is difficult to provide protection for all applications. If erratic system behavior is experienced, then the source of the "noise" must be suppressed with either a resistive/capacitive type of suppressor on AC coils, or "Avalanche" type diodes on DC coils.

NOTE:

The *Ultra Advantage Sequential Servo Roll Feed* is fully protected by line circuit breakers.

NOTE:

The electrical control enclosure is supplied with a stand/support, which may be placed in any convenient location. The enclosure may also be mounted in any fixed location as long as the cabling is adequate to reach the feed. It is not recommended that the electrical enclosure be mounted directly to the press. The vibrations caused by the punch press can result in damage to the control system

1.3 LOADING THE FEED (PRESS APPLICATION)

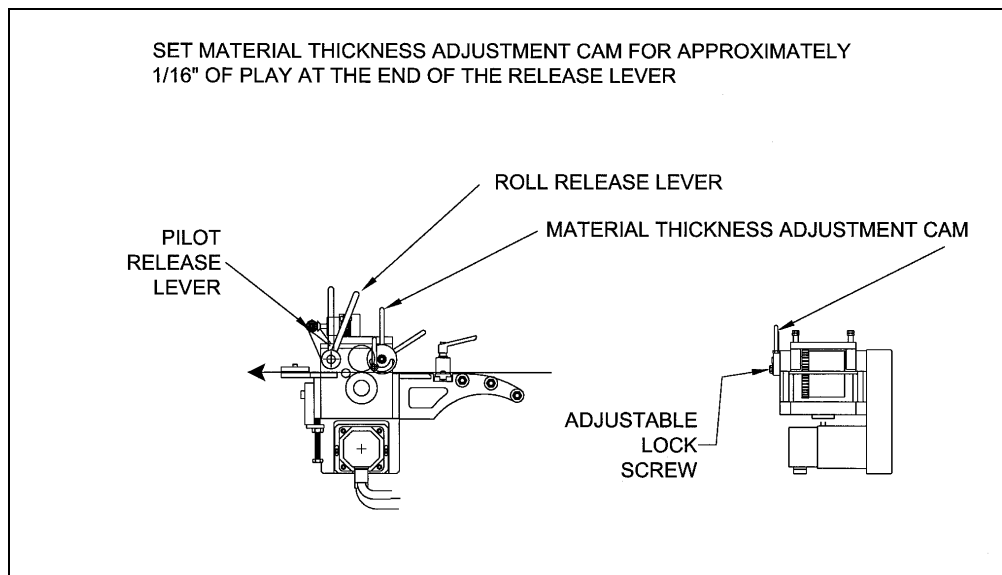

FIGURE 3

Prior to this step, the electrical control must be powered up and all needed parameters are loaded. (Refer to the *Ultra Advantage Sequential Servo Feed Operating Manual*.)

NOTE:

This example is based on using PLS (Programmable Limit Switch), but all PLS timing notes can be easily translated to other forms of timing.

1. Put the *Ultra Advantage Sequential* control into "MANUAL MODE". Record the present settings of the Feed Cam, Reset Cam, and Pilot Release Cam into a job set-up record sheet for future reference to the job.
2. Adjust the roll clamping force by pre-loading the two die springs located on top of the feed housing. Normal setting for the roll force spring pre-load is two full turns clockwise from finger tight (factory preset). Be sure to use the jam nut to lock the setting.
3. Open the feed rolls by pulling on the Roll Release Lever. Insert the material through the feed rolls and close the feed rolls by releasing the Roll Release Lever.
4. Adjust the material thickness using the Material Thickness Adjustment Cam and Adjustable Lock Screw. Refer to the **FIGURE 3** for proper setting.
5. Using the **Jog Forward** button on the jog pendant, advance the material up to the entrance of the die (far enough where the punches would not pierce the material).
6. Check the vertical alignment of the strip. If necessary, adjust the pass line of the feeder so that the material is at the proper height.
7. Assuming that the press shut height and the tool are set up properly, jog the press one or two strokes without the feed working.

8. Jog the press down slowly observing when the longest pilot would engage the pilot hole in the material if the material were there. (Refer to Figure 4.) Note the press positional readout and put this setting into your Programmable Limit Switch (PLS) for the 'Pilot Release On' setting. The 'Pilot Release Off' setting, in most cases, should be 180°. (See Figure 5.) Some drawing applications require the rolls to remain open past 180°.

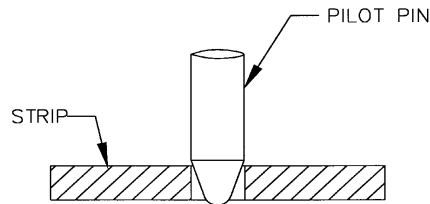

FIGURE 4

9. Continue to jog the press slowly until the longest pilot just comes out of the material. Note the press positional readout and put this setting into your PLS for the 'Feed Cam On' setting. Set the 'Feed Cam Off' point so that there is enough time to complete the feed length and enough time to stop the press, if there is a feed fault. (See Figure 5.)
10. Set the 'Reset Cam On' for 180 degrees and 'Reset Cam Off' for 200 degrees. This setting should never need changing. (See Figure 5.)

1.4 LOADING THE FEED (PUNCHING BENCH APPLICATION)

Prior to this step, the electrical control must be powered up and all needed parameters are loaded. (Refer to the *Ultra Advantage Sequential Servo Feed Operating Manual*.)

1. Adjust the roll clamping force by pre-loading the two die springs located on top of the feed housing. Normal setting for the roll force spring pre-load is two full turns clockwise from finger tight (factory preset). Be sure to use the jam nut to lock the setting.
2. Open the feed rolls by pulling on the Roll Release Lever. Insert the material through the feed rolls and close the feed rolls by releasing the Roll Release Lever.
3. Adjust the material thickness using the Material Thickness Adjustment Cam and Adjustable Lock Screw. Refer to the **FIGURE 3** for proper setting.
4. Using the **Jog Forward** button on the jog pendant, advance the material up to the exit of the last punch station.
5. Check the vertical alignment of the strip. If necessary, adjust the pass line of the feeder so that the material is at the proper height.
6. Assuming that the punches are set up properly, fire the punches one by one manually, making sure they go all the way down and up without any problem.
7. Using the jog pendant move the material forward, observing that it is moving through the bench with no visible difficulties.

1.5 USING A BACKUP MOVE

In some applications with a cutter the material needs to be moved backward, away from the blade, to prevent bending it up by the blade.

In this case the wiring must be considered very carefully.

The backing up the material in a Press application requires:

- A cutter bottom position sensor to be wired to the control.

The backing up the material in a Punching Bench application requires:

- A cutter bottom position sensor to be wired to the control:
- A cutter top position sensor to be wired to the control.

For a comprehensive description, refer to the *Ultra Advantage Servo Roll Feed* Operation Manual and electrical schematic A-18164-06.

1.6 RUNNING THE FEED

Put the *Ultra Advantage Sequential* into “Auto” by pressing the **Cycle Start** button. The *Ultra Advantage Sequential Servo Roll Feed* will now follow the press until it is stopped by the Operator, counter, emergency stop, or feed error.

TYPICAL 180 DEGREE FEED ANGLE (FROM 260 DEGREES TO 80 DEGREES) WITH MECHANICAL PILOT RELEASE IN A POWER PRESS APPLICATION:

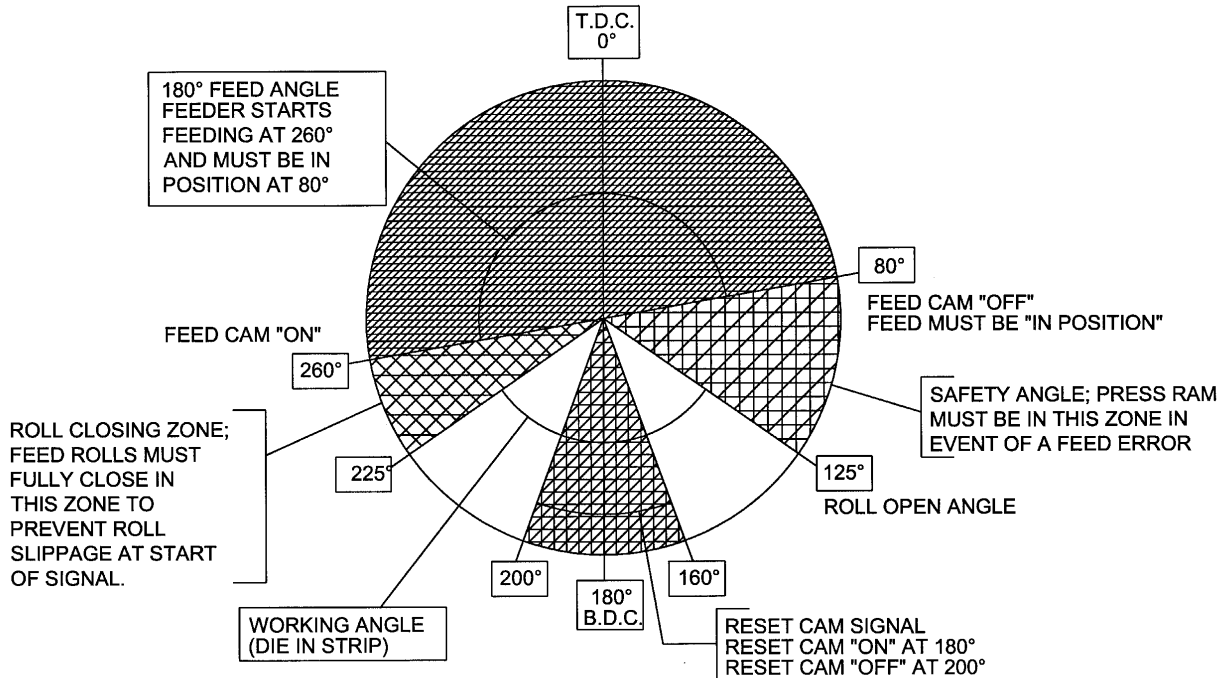

FIGURE 5

NOTES ABOUT 'POSSIBLE PROBLEM TOOLING': *

- A tight die, one that is not square, or has other tooling problems, will cause significant difficulty and downtime. Accuracy in feeding is directly related to how easily the feeder can position the strip in the die. Binding, bad part ejection, or sticking parts may cause the material to "jam" in the die.
- The *Ultra Advantage Sequential Servo Roll Feed* will "try" to overcome the "jam-up" by applying more power to the rolls.

ONE OF FOUR OUTCOMES WILL RESULT:

1. The feed will continue to try to move the strip (if the rolls do not slip) until the Feed Cam opens. A **SYNC FAULT** Error will occur and the press will be stopped by the feeder if the press control is integrated to the feed control.
2. The feed will apply more power to the rolls, causing them to slip on the material. This produces a "short-feed". In reality the feeder did not "miss-feed". The rolls were positioned properly, the strip did not keep up, causing the die to close and a miss-hit is produced.
3. The feed applies more power to a thin strip, causing the material to buckle somewhere between the feed and the die set. The feeder positioned the strip accurately, it just did not occur in the die set.
4. The feed tries to apply so much power to a heavy strip in order to move it, that excessive current is drawn by the servo drive. This results in the drive shutting down to protect itself and in doing so stops the press if the press control is integrated to the feed control.

NOTE: The feed detected a problem and emergency-stopped the press before the die closed. In using the *Ultra Advantage Sequential Servo Roll Feed*, you in fact have added a "die protection" system to your tooling.

* A tooling problem is a problem caused by tooling and not the Feeder itself.

2 PNEUMATIC PILOT RELEASE

During operations such as forming or using pilots, the purpose of the Pneumatic Pilot Release is to release the strip from the feeder rolls. This allows the material to be adjusted slightly any time during the press cycle.

The pneumatic release mechanism is mounted centrally on the top of the feeder using (4) M8 screws and washers in slotted holes, which can be accessed by removing the cover. The slots are to allow proper alignment and adjustment with the release arm and roller.

Open the rolls allowing clearance between the upper roll and the material approximately 0.010"/0.25 mm. (Use a shim on top of the material, if needed.)

Position the Pilot Release mechanism so that with the cylinder piston fully extended, it is against the roller.

The SRF Pilot Release mechanism is pre-assembled, only needing outside air and electrical connections. For air connections, refer to Figure 6.

The release is operated by applying the appropriate voltage signal to actuate the 3-way solenoid valve to open the feeder rolls. This power signal can come from a source such as a rotary cam switch.

The solenoid valve, located on the release, is provided with a cable attached to the solenoid valve for connecting the power signal leads.

Air pressure of 80-100 PSI is required for proper operation of the release. A 1/4" tubing fitting is provided for the air supply connection.

Mechanical pilot releasing is also possible by simply loosening the release arm and repositioning to either side of the pneumatic release and aligning with the strike.

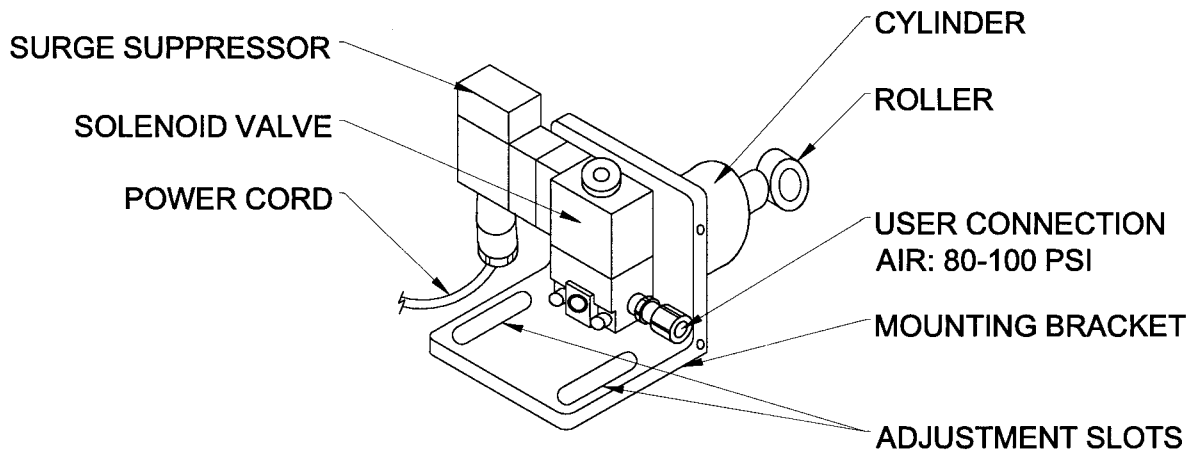

FIGURE 6

3 MAINTENANCE

The *Ultra Advantage Sequential Servo Roll Feed* needs very little maintenance to keep the system operating at its optimum performance.

- This precision equipment must be kept as clean as possible. This is especially important if large amounts of air suspended oil mists in combination with “dirty metals” are used. The resulting abrasive dust can attach itself to the feed rolls and other surfaces, leading to premature wear on many parts.
- The roll release system requires a clean, dry air supply.
- Some bearings used on the feeder are fully sealed and maintenance-free roller ball bearings. The exceptions are provided with standard “zerk” type grease fittings. They should be lubricated with a good grade of high pressure bearing grease. The frequency of lubrication will depend on the overall usage of the system. A small “shot” once a day is a good starting point. The feed roll gears set should be coated with a small amount of open gear grease.
- The main drive belt should be checked periodically for tightness. It can be adjusted by loosening the two fasteners on the motor adjuster plate, applying downward pressure on the motor adapter plate, and retightening. **ERRATIC MOTOR BEHAVIOR WILL BE EXPERIENCED IF THE DRIVE BELT IS LOOSE!**
- All fasteners should be checked for tightness at regular intervals.
- The electrical system also requires very little maintenance. Keep the enclosure clean and replace any burned indicator bulbs. Do not expose the electrical enclosure to constant high temperatures. Possible system failure could result.
- The Feeder’s electrical enclosure door is sealed to prevent oil and contaminants from entering inside. However, small gaps can be found around some sealing surfaces and faceplates. It is a good idea, therefore, to keep the console free of stamping oils and fluids, which could “seep into” the enclosure. Most often, these oils are carried by the Operator’s hands or by air mist lubrication etc.
- All of the above guidelines should be added to your existing pressroom Preventive Maintenance (PM) Program.

4 ROLL FEED PARTS LIST

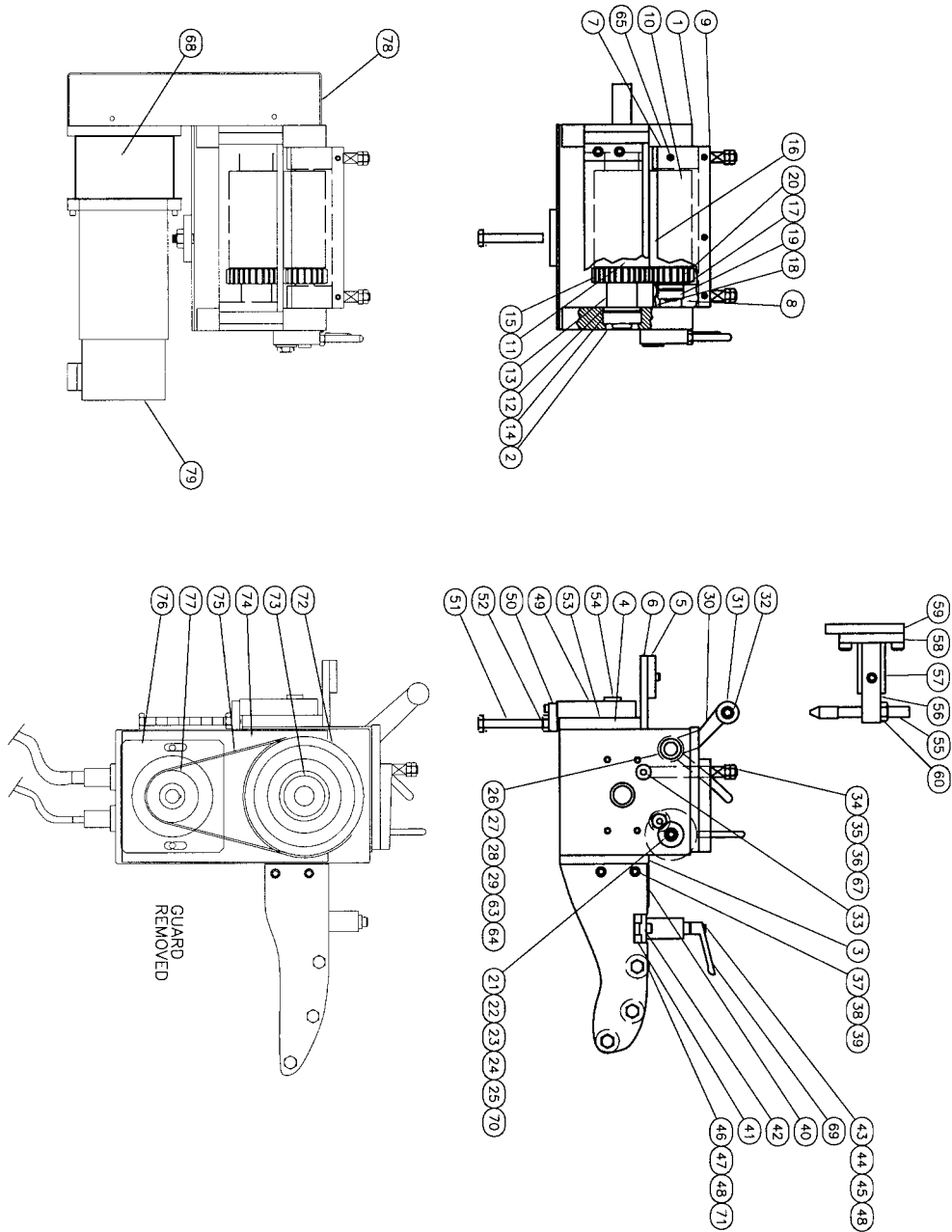

FIGURE 7

ITEM	QTY	DESCRIPTION
1	1	BEARING HOUSING - LEFT SIDE PLATE
2	1	BEARING HOUSING - RIGHT SIDE PLATE
3	1	PLATE- CASCADE MTG.
4	1	PLATE - FEED MTG.
5	1	PLATE - EXIT
6	1	PLATE - MATERIAL HOLD DOWN
7	1	BRACKET - UPPER ROLL, LEFT
8	1	BRACKET - UPPER ROLL, RIGHT
9	1	PLATE - UPPER ROLL
10	1	GUARD - ENTRY
11	1	ROLL - LOWER
12	2	DUST SHIELD - LOWER
13	1	SPACER - LOWER
14	2	BEARING - LOWER
15	1	GEAR - LOWER
16	1	ROLL - UPPER
17	2	DUST SHIELD - UPPER
18	2	RETAINING RING
19	2	BEARING - UPPER
20	1	GEAR - UPPER
21	1	SHAFT - THICKNESS ADJUSTMENT
22	1	LEVER - THICKNESS ADJUSTMENT
23	1	CAM ECCENTRIC BUSHING
24	1	BUSHING - TAPER LOCK - INNER
25	1	BUSHING - TAPER LOCK - OUTER
26	1	SHAFT - ROLL RELEASE
27	2	BEARING, NEEDLE
28	2	WEAR PAD
29	1	RELEASE LEVER - MANUAL
30	1	RELEASE LEVER - MECHANICAL
31	1	BEARING - ROLL RELEASE
32	1	SPACER - RELEASE BEARING
33	2	RETAINER, SPRING ROD
34	2	ROD, ROLL TENSION
35	2	SPRING, ROLL TENSION
36	1	SET SCREW M6 X 16
37	2	BRACKET - CASCADE
38	1	BLOCK - CASCADE MTG., LEFT

39	1	BLOCK - CASCADE MTG., RIGHT
40	1	PLATE - ENTRY
41	2	BAR - GUIDE ROLLER
42	2	CLAMP - GUIDE BAR
43	2	GUIDE ROLLER
44	4	SPACER - GUIDE ROLLER
45	2	NUT - T SLOT
46	3	ROLL - CASCADE, ENTRY
47	3	SHAFT - ROLL
48	10	BEARING - GUIDE & ENTRY ROLL
49	1	TRANSITION PLATE
50	1	ADJUSTMENT TAB
51	1	SCREW - HEX HD
52	1	NUT - HEX, JAM
53	1	KEY 22 mm x 5 mm x 110 mm
54	2	KEY 22 mm x 12 mm x 40 mm
55	1	STRIKER - RELEASE ACTUATOR
56	1	ARM - ADJUST
57	1	ARM - FIXED
58	1	BLOCK - MOUNTING
59	1	BRACKET - MOUNTING
60	1	NUT, STRIKER ADJUST
63	1	KEY 7 mm SQ x 35 mm
64	1	KEY 5 mm SQ x 15 mm
65	4	GREASE FITTING
67	4	NUT, M14, ROLL TENSION
68	1	PLANETARY GEAR REDUCER
69	2	HANDLE, WIDTH GUIDE ADJUSTMENT
70	1	HANDLE, THICKNESS ADJUSTMENT
71	6	NUT, HEX
72	1	TIMING SHEAVE
73	1	BUSHING
74	1	MOTOR BRACKET
75	1	TIMING BELT
76	1	MOTOR ADAPTER
77	1	TIMING SHEAVE
78	1	GUARD
79	1	SERVO MOTOR

WARNING

This equipment offers various means of operating or controlling machines. The operator must not be in or near the point-of-operation of the machine, or the operating parts of any equipment installed on the machine, or bodily injury could result. The EMPLOYER must post adequate warning signs onto the machine with proper warnings for his machine and the specific application to which the machine and equipment are being applied.

Occupational Safety and Health Act (OSHA) Sections 1910.211, 1910.212, and 1910.217 contain installation information on the distance between danger points and point-of-operation guards and devices. No specific references have been made to which paragraph of OSHA 1910.211, 1910.212, 1910.217 or any other applicable sections because the paragraphs may change with each edition of the publication of OSHA provisions.

All equipment manufactured by us is designed to meet the construction standards of OSHA in effect at the time of sale, but the EMPLOYER installs the equipment so the EMPLOYER is responsible for installation, use, application, training, and maintenance, as well as adequate signs on the machine onto which this equipment will be installed.

Remember, OSHA says that the EMPLOYER must use operating methods designed to control or eliminate hazards to operating personnel.

It shall be the responsibility of the EMPLOYER to establish and follow a program of periodic and regular inspections of his machine to insure that all their parts, auxiliary equipment, and safeguards are in a safe operating condition and adjustment. Each machine should be inspected and tested no less than weekly to determine the condition of the machine. Necessary maintenance or repair of both shall be performed and completed before the machine is operated. The EMPLOYER shall maintain records of these inspections and the maintenance work performed.

Our Company is not responsible to notify the user of this equipment of future changes in State or Federal laws, or construction standards.

SAFETY PROGRAM

Accident free operation will result from a well developed, management sponsored and enforced safety program. Of vital importance to any successful program is the proper selection of guards and devices. However, there is no safety device that will bring "automatic" safety to your operation.

Of equal importance to this proper selection of the guard and the device is the training of your personnel. Each person must be trained as to the operation of the guard or safety device, highlighting why they have been provided on the equipment. Rules for safe operating should be written and enforced at all times. A final major concern of an effective safety program is regularly scheduled inspection and maintenance of all of the equipment.

To ensure continued safety at all times, top management, line supervision, safety engineers and all employees must assume their proper share of the responsibility in the program. Only as a group, one that knows your own operation and its problems, can you carry out an effective safety program.

To assist you in the development of and continued use of safety programs, many safety minded groups have made guidelines available to you. However, you must know when and how to apply these guidelines. The manufacturer provides information to assist you in properly adjusting and maintaining your equipment. There is no short cut to proper safety; therefore, it is recommended that you comply with their recommendations at all times.

WARRANTY

We warrant our new parts against defects under normal use and service for a period of 12 months after date of shipment. Our obligation under this warranty is limited to replacing or repairing (at our option) the defective part without charge, F.O.B. our plant in Bloomfield, Connecticut. The defective part must be forwarded to our plant, freight prepaid, for our inspection prior to replacement or repair. EXCEPT AS EXPRESSLY PROVIDED HEREIN, THIS WARRANTY IS IN LIEU OF ALL OTHER WARRANTIES, EXPRESS OR IMPLIED, INCLUDING A WARRANTY OF MERCHANTABILITY OR FITNESS FOR A PARTICULAR PURPOSE. Furthermore, the seller does not warrant or represent that the equipment complies with the provisions of any law, particularly including the Occupational Safety and Health Act of 1970, and regulations promulgated thereunder. In no event shall we be liable for special, indirect incidental or consequential damages, however rising.



P/A INDUSTRIES INC. 522 Cottage Grove Road ■ Bloomfield, Connecticut 06002-3191 U.S.A.
Toll Free 1-800-243-8306 ■ Worldwide 1-860-243-8306 ■ Fax 1-860-242-4870
Website <http://www.pa.com> ■ E-Mail service@pa.com